

The DSP30/60 semiconductor switch pack is controlled by DMX512. The outputs may be powered separately from the main 230V supply with voltages from 12 to 230V ac. (see next page). With ac supply the loads are switched at zero-cross. **If a separate Load supply is used for dimming - the zero-cross must be deactivated!** The maximum current of all outputs must not higher than 16A, a single channel is able to lead 1A if fitted with fuse T1A.

(the switching Hysteresis is: >60% / 153 digit → ON, less than 40% / 102 digits → OFF.)
Pay attention to a good air flow to the pcb in use with high Power consumptions (>1000W)

Connection scheme and further Information on the next page.

Following Modes are available with DIP-Switch S4:

- S4.1 DMX Error, Signal absent open = hold last scene / all channels off
- S4.2 60/30 channels open = 60 channels / 30 channels
- S4.3 Zero- crossing open = switch on, at zero cross / free running (for Dimming)
- S4.4 unused
- S4.5 unused

This piece of equipment needs the 230V Line for power supply. It is provided to the installation into a control cubicle, an comparable piece of equipment or other closed system-unit cover.
It only may be installed and taken in operation by technically trained persons.
Before opening cover or handling with disconnect all Lines, leading mains voltage !

Fuses

T250mA (control circuit)

F 50mA (zero cross circuit)

60

← Outputs →

!! all Load - fuses max. 1A slow acting

31

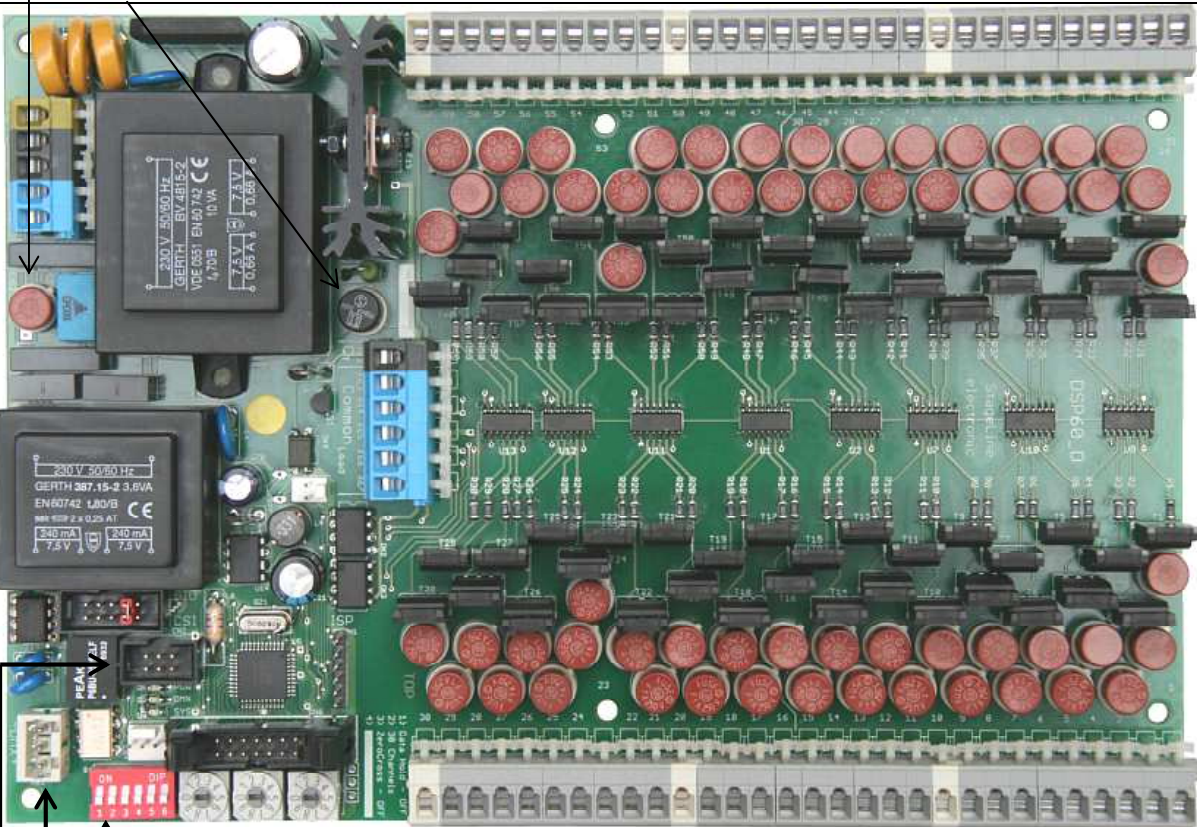

DMX Connector to external LED pcb

LED Modes

Start ADR/Control

100 10 1

30

← Outputs Load →

connecting Power Supply - see next page

1

Electrical connection diagram: Power Supply

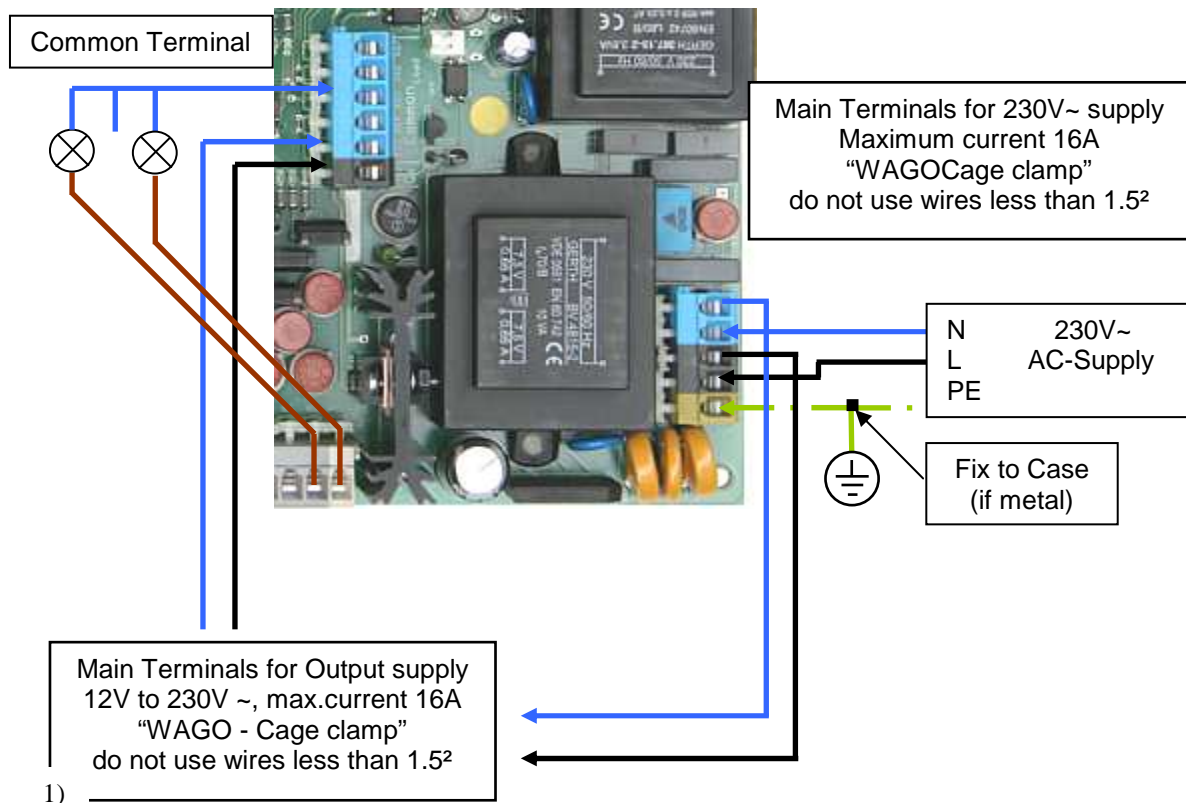

The drawing shows a typical application for 230V~ Load Outputs. In this case use the interconnecting cables to connect the blue (N) and black (L) terminals as shown.

For other voltages or galvanic isolation use e.g. a transformer ¹⁾.

Take into account that there is no fuse in the Outputs main supply ! A separate 16A circuit breaker is only necessary when the main Power supply is capable of more than 16Amps.

With power consumptions higher than 1000W it is very important to have a good air flow along the pcb!

Electrical connection diagram: LED's, DMX Input and Switches: Mode, DMX address

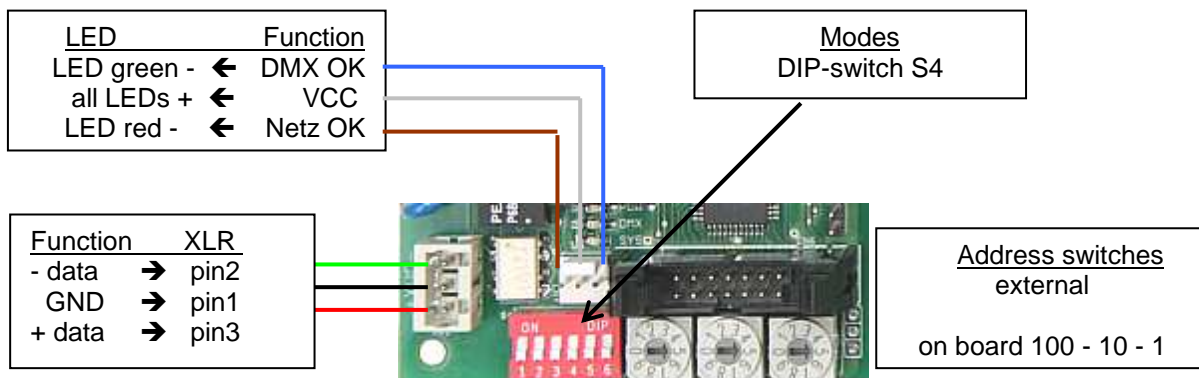

The DMX connector is an cage-clamp type, to open a clamp you should use a 2.5mm flat screw driver. To fix the clamp in the open state put the screwdriver in the square hole near the round hole the wire has to put in.